

Instructions for Using Webster Tri-Polar Oscillator Types M-5, M-37, K-37, K-60, L-60

TO START ENGINE.

1. Move timing lever (J, Fig. 2) to the right. This is the retarded or starting position.
2. Turn fly wheels forward until oscillator trips, and stop in this position. The crank should now be set on dead center.
3. Cock oscillator with starting lever (A) as in (Fig. 1).
4. Open needle valve. Close damper or hold hand over intake pipe and turn fly wheels forward about a quarter of a revolution to draw charge of gas into cylinder.
5. Pull fly wheels back against compression and trip oscillator quickly by pressing down on starting lever (A). This will start the engine. After a few explosions, move timing lever (J) to the left. This is the advanced or running position.
6. Adjust needle valve of mixer until best results are obtained. Small engines may be started by cranking, care being taken to have timing lever (J) in retarded position.
7. In case bracket is equipped with a priming cup, starting can be made as follows: Carry out directions (1, 2 and 3). Open needle valve as in (4). Fill priming cup with gasoline. Turn fly wheel forward about one-fourth of a revolution and open priming cup valve quickly so that fuel is drawn in by suction. By carrying out direction (5) the engine will start.

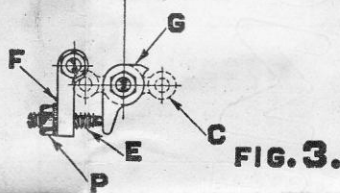
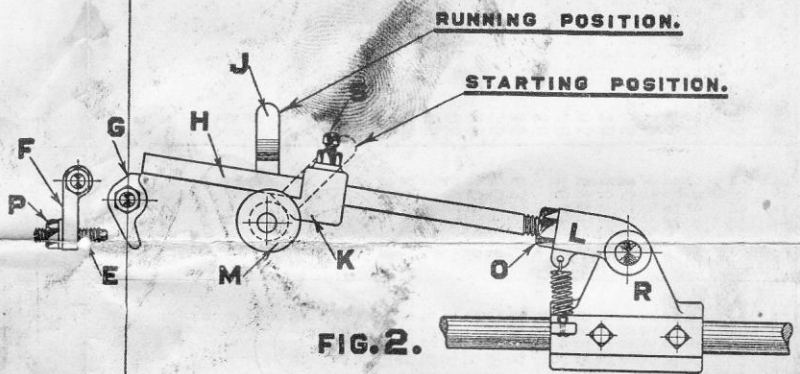
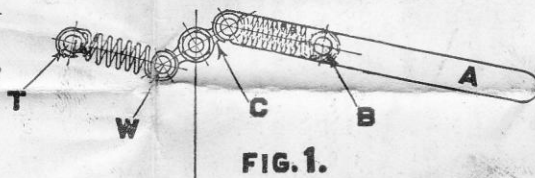

TO TEST FOR SPARK.

- IMPORTANT!** Remove oscillator and bracket from engine and trip oscillator with starting lever (A). If a weak spark or no spark occurs at the points there are but three reasons for it.
- No. 1. The adjustment of screw (E) in the electrode arm (F) may not be correct. The correct position of screw (E) is when it just touches the tail of push finger (G) when the spring arm (C) is in a horizontal position as in (Fig. 3). Always be sure to tighten lock nut. With the screw (E) in this position the points will always be together, and a maximum spark will always be obtained. As the points wear down the screw (E) must be adjusted.
 - No. 2. The connections between oscillator and stationary or insulated electrode on ignitor plug may be short-circuited. By this is meant the brass terminal on the electrode and the wire running from oscillator to it. Care must be taken not to bend this brass terminal or connecting wire from oscillator to terminal in such a way that either will touch any part of bracket or oscillator, as this will cause a short-circuit and no spark will occur at the points. The wire may also be broken. This can be easily replaced by removing the cover which is under magnets. Use good wire.
 - No. 3. The insulation of the stationary electrode is dirty or broken down, in which case the insulation must be renewed or cleaned.

TO ATTACH WEBSTER OSCILLATOR.

1. Remove battery ignitor from cylinder and ignitor trip rod from valve rod.
2. Remove bolts from governor detent plate and attach valve rod clamp (R) complete with push rod (H), wedge (K), and journal (L) on the valve rod as shown by (Fig. 2), fastening over governor detent plate by screws (D). In putting on valve rod clamps be sure to get governor detent plate in the same position it was before. This should be set so that the highest point on the cam will just release the catch.
3. Put new gasket on oscillator bracket and bolt to cylinder, being careful to lift push rod (H) above the roller (M) in doing this. The push rod (H) should lie freely in roller (M), but if it binds on either side, correct by shifting the washers on sides of push rod journal (L).
4. Attach oscillator to bracket and adjust screw (E) until it just touches push finger (G) when the spring arm (C) is in horizontal position, as in (Fig. 3). Tighten lock nut (P).

TO ADJUST AND TIME WEBSTER OSCILLATOR.

1. Place engine crank in firing position. To do this, set engine crank 8 degrees below inner dead center on compression stroke, for every 100 revolutions per minute of the engine.
2. Move timing lever (J) to the left or running position. Place starting lever (A) on long spring stud and cock oscillator as in (Fig. 1).
3. Adjust length of push rod (H) in journal (L) until end of push rod just touches tip of push finger (G). Tighten lock nut (O).
4. Move wedge (K) toward oscillator until lower edge of push rod (H) just clears push finger (G). Tighten set screw and lock nut.
5. Remove starting lever (A) and attach oscillator terminal wire to insulated electrode. Turn engine over slowly and if properly timed, oscillator will trip off at firing position. To make engine fire earlier, move wedge toward oscillator and in the opposite direction to make it fire later.
6. Starting lever (A) is also a gage to determine the angle to which the oscillator should always be cocked. Be sure that the push rod (H) operates the oscillator to this angle when timing lever (J) is in the running position as in (Fig. 2).

CARE OF OSCILLATOR.

The oscillator being a mechanical device requires the same attention regarding lubrication as does the engine itself.

Oil frequently the two main bearings of the oscillator, the trip roller and the movable electrode. Use a good quality of oil. Avoid the use of heavy oil. In cold weather use very light oil, and if the electrode and main bearings have a tendency to stick, wash them out with a few drops of kerosene.

Ignitor points may be cleaned without removing bracket from engine by sliding movable electrode back and forth from the outside.

Never remove the magnets from the oscillator, as they will immediately lose much of their strength.

Never take the oscillator apart. It contains absolutely no brushes or rubbing contacts of any kind. Dismantling can result only in derangement of the machine and permanent injury thereto.

Oil the four spring roller pins (T) and (W) (Fig. 1) and clean dust off daily.

KEEP OSCILLATOR CLEAN

The Webster Electric Co., Racine, Wis., U. S. A.

Webster Tri-Polar Oscillator

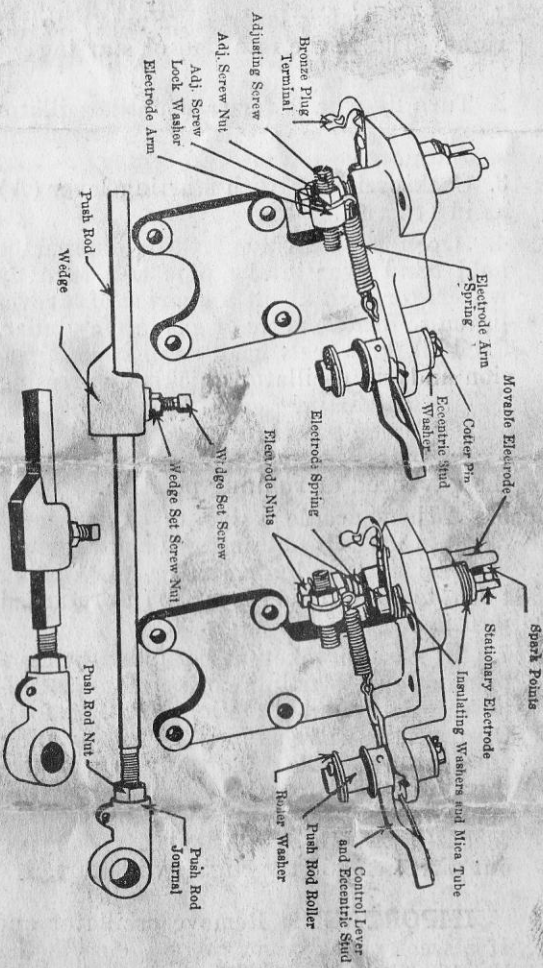

Spare Part List of Attachments for Types M5, M37, K37, K60, L60

Description	Type	M5		M37		K37		K60		L60	
		1 1/2 H.P.	303M5	1 1/2 H.P.	303M37	1 1/2 H.P.	303K37	2 1/4 H.P.	303K60	6 H.P.	303K60
Lentor Plug Bracket (Complete)		6.00									
Adjusting Screw (Complete)		.10	358J2	.10	358J2	.10	358J2	.10	358J2	.10	358J2
Adjusting Screw Lock Washer		.05	699J1	.05	699J1	.05	699J1	.05	699J1	.05	699J1
Bronze Plug Terminal		.05	357J1	.05	357J1	.05	357J1	.05	357J1	.05	357J1
Control Lever and Eccentric		.15	546K7	.15	546J2	.15	546K1	.15	546K7	.15	546K7
Cotter Pin		.75	362J2	.75	362J2	.75	362J2	.75	362J2	.75	362J2
Eccentric Stud Washer		.05	697J17	.05	697J17	.05	697J17	.05	697J17	.05	697J17
Electrode Arm Spring		.05	680K3	.05	680K3	.05	680K3	.05	680K3	.05	680K3
Electrode Arm Washer		.25	320K29	.25	320K29	.25	320K29	.25	320K29	.25	320K29
Electrode Lock Washer (Stationary or Movable)		.10	545K2	.10	545K2	.10	545J1	.10	545K2	.10	545K2
Electrode Nut (Sta. or Movable)		.05	699K1	.05	699K1	.05	699K1	.05	699K1	.05	699K1
Electrode Spring		.05	355K	.05	355K	.05	355K	.05	355K	.05	355K
Electrode Washer (Stationary)		.10	572K1	.10	572K1	.10	572K1	.10	572K1	.10	572K1
Insulating Washers		.05	353K1	.05	353K1	.05	353K1	.05	353K1	.05	353K1
Key (Woodruff)		.05	542J	.05	542J	.05	542J	.05	542J	.05	542J
Mica Tube		.20	359K15	.20	359K8	.20	359K15	.20	359K8	.20	359K8
Movable Electrode with Point		.75	351K15	.75	351M37	.75	351K37	.75	351K60	.75	351K60
Printing Cup		.35	632K	.35	632K	.35	632K	.35	632K	.35	632K
Push Rod Journal		.30	463K1	.30	463K1	.30	463K37	.30	463K1	.30	463K1
Push Rod Nut		.30	482K1	.30	482K1	.30	482K1	.30	482K1	.30	482K1
Push Rod Roller		.05	447K1	.05	447K1	.05	447K1	.05	447K1	.05	447K1
Roller or Journal Washer		.05	702J19	.05	702J19	.05	702J19	.05	702J19	.05	702J19
Spark Points (each)		.20	479K1	.20	479K1	.20	479K1	.20	479K1	.20	479K1
Stationary Electrode with Point		.60	352K8	.60	352K8	.60	352K15	.60	352K8	.60	352K8
Wedge Set Screw and Nut, (specify size)		.20	363K7A	.20	363K7A	.20	363K7A	.20	363K7A	.20	363K7A
Wedge Set Screw Nut (give size of Screw)		.05	703K2	.05	703K2	.05	703K2	.05	703K2	.05	703K2
			357J1		357J1		357J1		357J1		357J1

Be sure when ordering parts to give engine horse power, oscillator type and number.

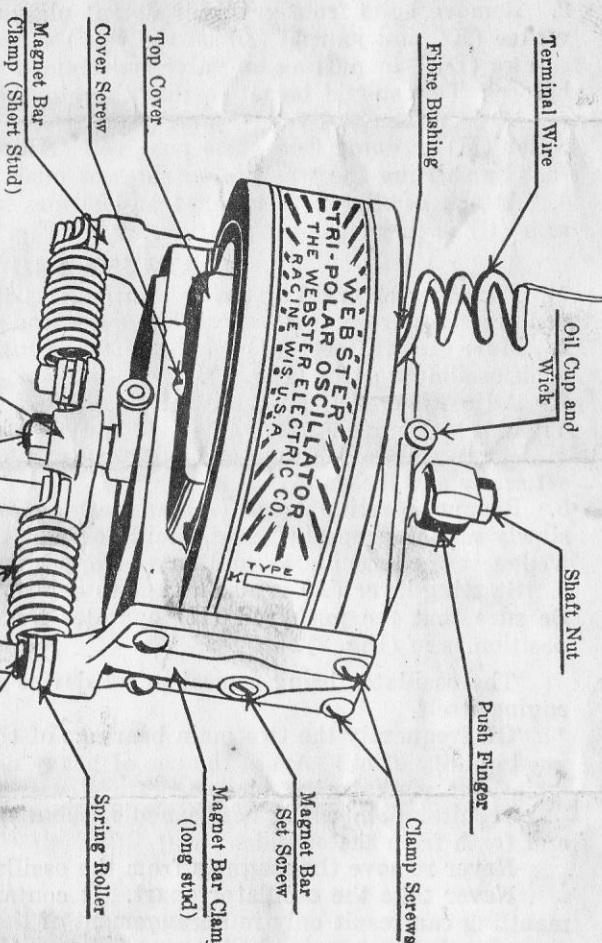

Spare Part List of Oscillator Types M5, M37, K37, K60, L60

Description	Type	M5		M37		K37		K60		L60	
		1 1/2 H.P.	303M5	1 1/2 H.P.	303M37	1 1/2 H.P.	303K37	2 1/4 H.P.	303K60	6 H.P.	303K60
Base Stud Lock Washer		\$0.05	699K1	\$0.05	699K1	\$0.05	699K1	\$0.05	699K1	\$0.05	699K1
Base Stud Nut		.05	355K	.05	355K	.05	355K	.05	355K	.05	355K
Clamp Screw		.05	567K	.05	567K	.05	567K	.05	567K	.05	567K
Fibre Bushing		.05	328J	.05	328J	.05	328J	.05	328J	.05	328J
Inductor Spring		.10	331K	.10	331K	.10	331K	.10	331K	.10	331K
Key (Woodruff)		.05	542J	.05	542J	.05	542J	.05	542J	.05	542J
Magnet Bar Clamp (Long Stud)		.25	307M	.25	307M	.25	307K	.25	307K	.25	307K
Magnet Bar Clamp (Short Stud)		.25	307M	.25	307M	.25	307K	.25	307K	.25	307K
Magnet Bar Set Screw		.05	566K	.05	566K	.05	566K	.05	566K	.05	566K
Oil Cup		.15	495K	.15	495K	.15	495K	.15	495K	.15	495K
Oil Wick		.05	497K	.05	497K	.05	497K	.05	497K	.05	497K
Push Flinger		.50	302K3	.50	302K3	.50	302K3	.50	302K3	.50	302K3
Shaft Nut		.05	357J1	.05	357J1	.05	357J1	.05	357J1	.05	357J1
Shaft Nut Lock Washer		.05	699J2	.05	699J2	.05	699J2	.05	699J2	.05	699J2
Spring Arm		.50	502K	.50	502K	.50	502K	.50	502K	.50	502K
Split Ring		.05	582K	.05	582K	.05	582K	.05	582K	.05	582K
Spring Roller		.15	314K	.15	314K	.15	314K	.15	314K	.15	314K
Starting Lever		.20	577K	.20	577K	.20	577K	.20	577K	.20	577K
Terminal Screw		.05	701K	.05	701K	.05	701K	.05	701K	.05	701K
Terminal Wire		.10	552J	.10	552J	.10	552J	.10	552J	.10	552J
Top Cover		.35	340M	.35	340M	.35	340K	.35	340K	.35	340K
Top Cover Screw		.05	341J	.05	341J	.05	341J	.05	341J	.05	341J

THIS LIST SUPERSEDES ALL FORMER PRICES, 6-1-17. DEFECTIVE PARTS IF ANY, MUST BE RETURNED FOR REPLACEMENT OR CREDIT.