

HERE IT IS!

WICO *Replacement Magneto Kit*

NO PARTS TO CHANGE



PACKAGED FOR DISPLAY

KIT CONTAINS

One Type XH-184 Magneto complete, and five Floats.
Includes complete Installation, Adjusting and
Price Information

Only a Minor Impulse Lag Angle Adjustment Necessary



For base mounted, four-cylinder, clockwise rotation applications; includes the new Wico Tractor Magneto, the type XHG-4, and Floats or installation on over 35 popular Tractor and Industrial Engines.

List Price – Complete Kit \$44.00 Order by No. K5896

The Universal Base-Mounted Magneto Kit Featuring the Wico XH-184 Magneto

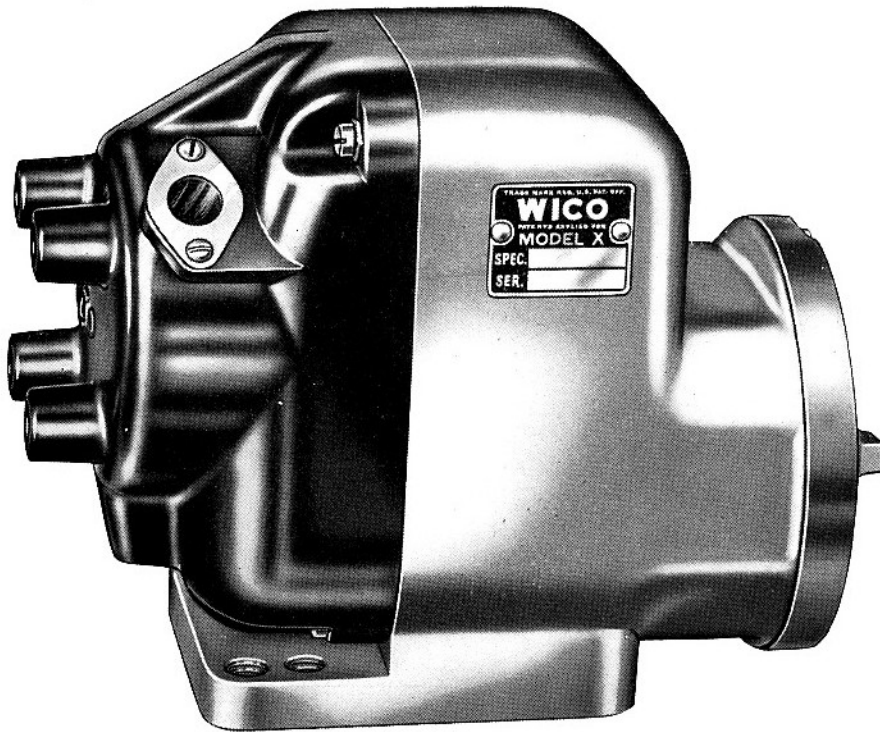

Magneto includes completely enclosed automatic impulse coupling, high output rotor, large aluminum housing, giving full protection against breakage of vital parts. Pre-lubricated, shielded ball bearing in the drive end. A quality magneto throughout.

With the K-5896 Kit you will have a replacement magneto for the following equipment :

BUDA—H205, H199, H173, WT4, FR, JY4, JK, FV-4
CASE COMBINES—C, K, P, Q, 1935 R Tractor, Case-Waukesha XA, FC, RRC
CATERPILLER—10, 15, 20
CONTINENTAL—Y-400, Y-410 engines
JOHN DEERE COMBINES—Balers with LYC. D, & HERC. IXB engines
FORDSON—1924 Tractor—(Use with Attachment)
HERCULES—IX AND ZX SERIES ENGINES
INTERNATIONAL—E4A, F4, Dixie 46, 10-20, W
MASSEY-HARRIS—Combines using Wauk. FC & Hercules IXB engines
WAUKESHA—XAH, FC, FK engines
WISCONSIN—AM-4, AP-4, FC Engines
and many others

WICO ELECTRIC COMPANY
WEST SPRINGFIELD, MASSACHUSETTS

January 20, 1947

CONVERSION OF XH-894 AND XH-184 MAGNETOS

Magnetos of the above specifications may be easily and quickly converted so that they can be used on a number of different applications.

In the case of the XH-894, which is a four-cylinder SAE, flange mounted, CW magneto, it is necessary to change either the lag angle or the drive cup or both, as shown in the following table:

SPEC.	MANUFACTURER	MODEL	LAG ANGLE	DRIVE CUP
1604	Avery & Sons	General	21	1806B
894	Allis Chalmers	WC, B, M, R, W, U	30	2361
894	J. I. Case	V, VC, VI, VO	15	2061A
1449	J. I. Case	S, SC, SI, SO	25	2361
1113	Cletrac	General	21	1806B
785	Continental	P-140, F-162, PF-124 F-140, Y-91, PY-91 PF-140, Y-69, PY-69	14	2061A
1023	Continental	F-124, PF-124, Y-71	20	2061A
1137	Hercules	IXA-3, IXB-3, IXF-3	21	1806B
1344	International	Tractor A, B, H, M	35	3750
1324	John Deere	Harvester (Herc. IXB-3)	21	1806B
623	LeRoi	W, X, K, 2C, CT, BX, B7	20	1806B
1344	McCormick	(IHC) A, B, H, M	35	3750
924	Novo	CW-95, CW-123	17	1806B
1222	Silver King	41	15	2061A

When changing the XH-184, which is a four cylinder, base mounted, CW magneto it is only necessary to change the lag angle and to use the float member indicated.

SPEC.	MANUFACTURER	MODEL	LAG ANGLE	FLOAT MEMBER
334-B	Buda	H205, H199, H173, WTU	27	1654
405-B	Buda	FR, JY4, JK, FV4	20	1654
175-B	Case Combine	(WAUK FK)	25	1654
	Case Combine	C, K, P, Q	24	1654
175-B	Case R Tractor-1935	WAUK FK	25	1654
175-B	Case Baler	1934 WAUK XA	22	1654

SPEC.	MANUFACTURER	MODEL	LAG ANGLE	FLOAT MEMBER
1577	Case	Using Wisconsin FC Engine	20	1654
	Case	RRC WAUK	24	1654
521	Caterpillar	10, 15, 20	35	1605 1654
41B	Continental	Y400, Y410	23	1654
17-D	John Deere	Combine & Baler (LYC D)	25	M-23X
873	John Deere	Combine & Baler (HERC IXB)	15	M-23X
184-B	Fordson Tractor	Jager ATT	30	M-23X
873	Hercules	IXB	15	1654
443-B	International Tractor	W	35	1606
481-B	International Tractor	10-20	30	1606
184-B	International Tractor	Late E4A, Early F4	30	1606
184-B	International Tractor	Late F 4	30	3866
184-B	International Tractor	Dixie 46, Early E4A	30	3365
435-B	Kohler Light Plant	WAUK	22	1654
862	Massey Harris	Combine WAUK FC	18	1654
863-B	Massey Harris	Combine HERC IXB	20	1654
175-B	McCormick Deering	Combine WAUK XAH	25	1654
175-B	Waukesha	XAH, 36HP, @ 1800 RPM	25	1654
734-B	Waukesha	XAH 1275 RPM	22	1654
731-B	Waukesha	FC 25 HP—1275 to 1500 RPM	17	1654
732-B	Waukesha	FC 1600 to 1800 RPM	20	1654
175-B	Waukesha	FK	25	1654
681-B	Waukesha	XA	22	1654
870	Waukesha	FC 1400 RPM	15	1654
962-C	Wisconsin	A M 4, AP 4	37	1654
1557	Wisconsin	FC	20	1654

Instructions for changing lag angle and the drive cup are given in the instructions section of the Service Manual.

REPLACEMENTS MADE EASY



*Wico Magnetos
for
Popular Tractors*

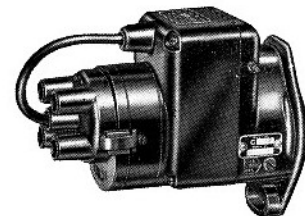

Tractor Model	No. Cyls.	Wico Spec.	Will Replace	List Price	Remarks
J. I. Case					
L Series	4	APH-548B	Case	\$56.00	Heavy Duty
V, VA-1, VC, VO, S, SC, SO	4	XH-1113B	Case, FM, Split	33.50	
D, DC, DO	4	XH-1113B		33.50	
Allis-Chalmers					
B	4	XH-894	FM	33.50	
K	4	XH-1022	FM	33.50	
L, LO	6	APH-969	FM	59.50	Heavy Duty
WC, M, W, UMC, UM	4	XH-894	FM, Wico	33.50	
B. F. Avery					
G	4	XH-1604		33.50	
Fate-Root-Heath					
Silver King "41"	4	XH-1222	Bosch, Wico	33.50	
Oliver Corp.					
Row Crop "70" After 223150	6	APH-488D	Bosch	59.50	Heavy Duty
Standard "70" Orchard "70" After 303506	6	APH-488D	Bosch	59.50	Heavy Duty
G (Cletrac)	4	XH-1113B		33.50	
E, AG (Cletrac)	4	XH-1128		33.50	M-23X Float
Row Crop "60"	4	XV-1348		37.00	

Tractor Model	No. Cyls.	Wico Spec.	Will Replace	List Price	Remarks	
John Deere Tractor Co.						
A	4 10000-424024	2	C-1042	FM	\$30.00	
A	424024-466400	2	C-477B	FM, Wico	30.00	
A	466401-487999	2	C-477B	Edison, Wico	30.00	
A	488000-	2	C-1042	Wico	30.00	
B	B1000-B89999	2	C-477B	FM, Wico	30.00	
B	B90000-	2	C-1042	Wico	30.00	
D	30400-130699	2	C-1263	Splitdorf	30.00	M-82X Float
D	130700-	2	C-477B	Edison, Wico	30.00	
G	G1000-	2	C-477B	Edison, Wico	30.00	
GP, O, W, WT, WSP, P		2	C-1263	FM, Edison, Wico	30.00	M-47X Float
H	H1000	2	C-1042	Wico	30.00	
L	621000-624999	2	XH-970B	Edison	30.00	Gear No. 5222
L	625000-	2	XH-909		30.00	Gear No. 4148
International Harvester						
W		4	XH-184	I. H. C.	33.50	1606 Float
10-15-20-30		4	XH-184	I. H. C.	33.50	1606 Float
A, B, H, M		4	XH-1344	I. H. C.	33.50	
1-9, T-9, W-9, T-14		4	XH-1769	I. H. C., FM	33.50	
Farm All — Late E4A, Early F4		4	XH-184B	I. H. C.	33.50	1606 Float
Farm All — Late F4		4	XH-184B	I. H. C.	33.50	3866 Float
Farm All — Dixie 46, Early E4A		4	XH-184B	I. H. C.	33.50	3365 Float

WICO ELECTRIC CO.

**WEST SPRINGFIELD
MASSACHUSETTS**

Distributed by:

Form S-100 3M 146
Printed in United States of America
EFFECTIVE JAN. 1, 1947